

# GLOBAL WIRELESS BROADBAND 2008 SUMMIT

## the **FUTURE** of WIRELESS BROADBAND

Middle East • Africa • South Asia • Russia • Central Asia  
30 - 31 March 2008, InterContinental Doha Hotel, Doha, Qatar

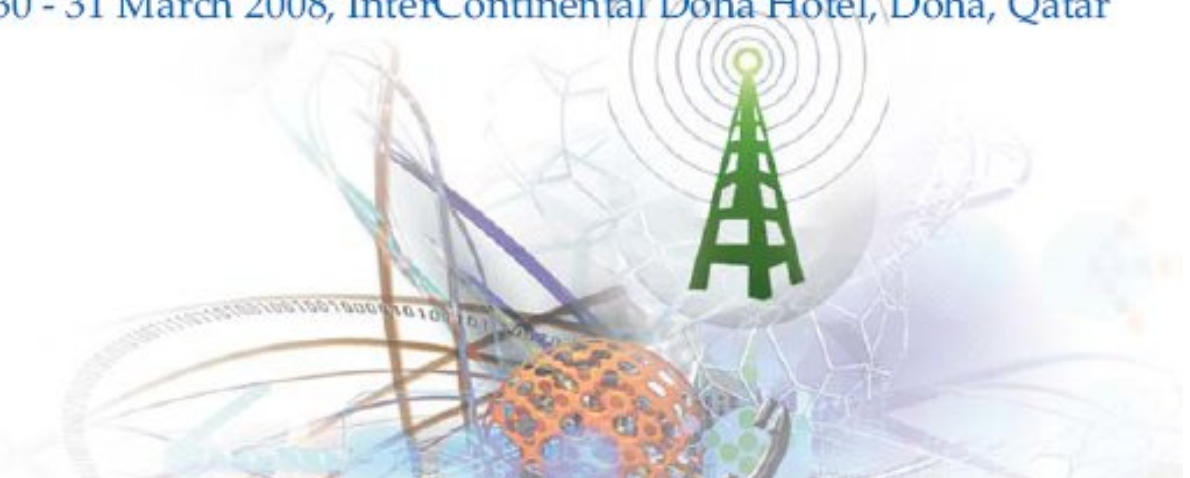

## WiMAX & IMS: Natural Partners

### **WiMAX & IMS: Natural Partners**

By

**Basit Sajjad Alvi**

Founder & CEO: Quasi-Stellar

Director Operations: The Right Connection

## Agenda

- WiMAX – IMS Comparison
- IMS Pros & Cons
- Market Scenario
- Challenges for Adoption
- Uniform Service Delivery
- conclusion

## Comparison

WiMAX is an Access Technology

IMS is a Session Architecture

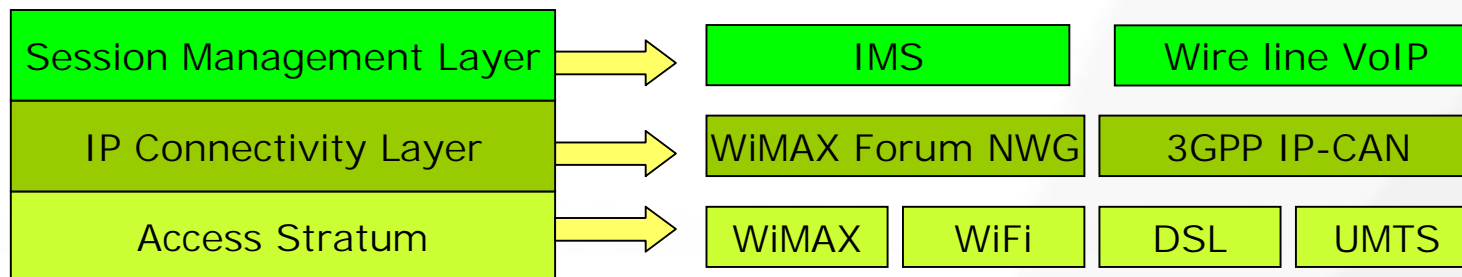
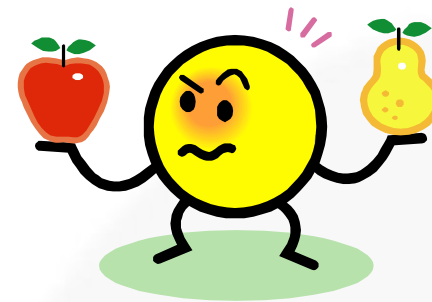

## Comparison (Contd.)

 Long live WiMAX; IMS is dead

Long live IMS; WiMAX is dead 

Long live WiMAX; UMTS is dead 

 Long live UMTS; WiMAX is dead

## IMS Pros And Cons

### □ Pros

- User Identity
- Security and confidentiality
- Policy and charging
- Session continuity
- Service Continuity

### □ Cons

- Dependence on various forms of SIM based technologies
- Operate in "Carrier walled garden"

## Market Scenario

- The WiMAX footprint stand at 80 countries now and More than 250 trials and deployment of WIMAX technology exist today (Report Intel and WiMAX forum)
- South Korea and Pakistan has the largest deployment of Mobile WiMAX.
- Korea's WiBRO service from KT and SK telecom provides coverage across metropolitan Seoul for more than 100,00 users
- Wateen in Pakistan has ordered more than 198,000 802.16e CPE from Motorola to offer nationwide fixed residential and business services.

## Market Scenario (Contd.)

- Tata Communication has announced that it will deploy the world's largest WiMAX network in India. Plans to hit 200,000 customers in retail segment alone in FY 2009.
- Wi-Tribe of Pakistan (previously Burraq-Tel); a subsidiary of Q-Tel has announced to offer service in three major cities by Mid 2009. Broadband mainly and voice as added feature.
- Pakistan Government is planning to offer 2.5 GHz for auction for broadband services.
- WiMAX equipment market grew 46% last year. Infonetics forecast the 2011 market at \$ 7.7 billion

## Challenges for Adoption

- ❑ Policies
- ❑ Security
- ❑ Charging
- ❑ Session Continuity
- ❑ Service Continuity

## IMS Has The Solution

- Unique identification
- Basic Service Continuity
- Security and authentication
- QoS and Charging Architecture

## Unique Identification

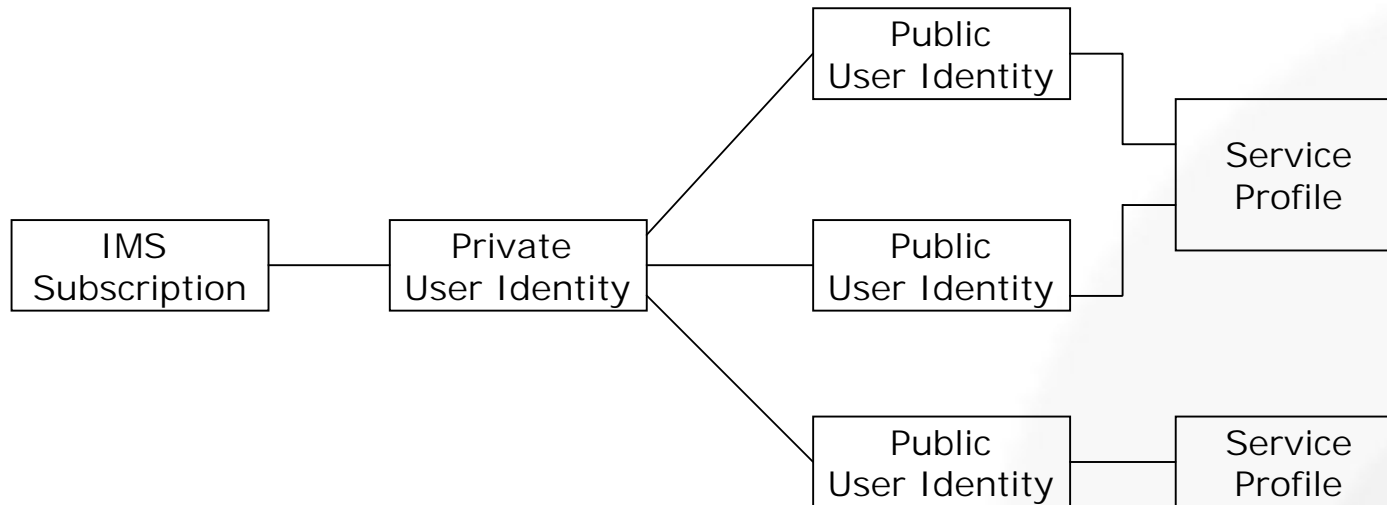

# Security & Authentication

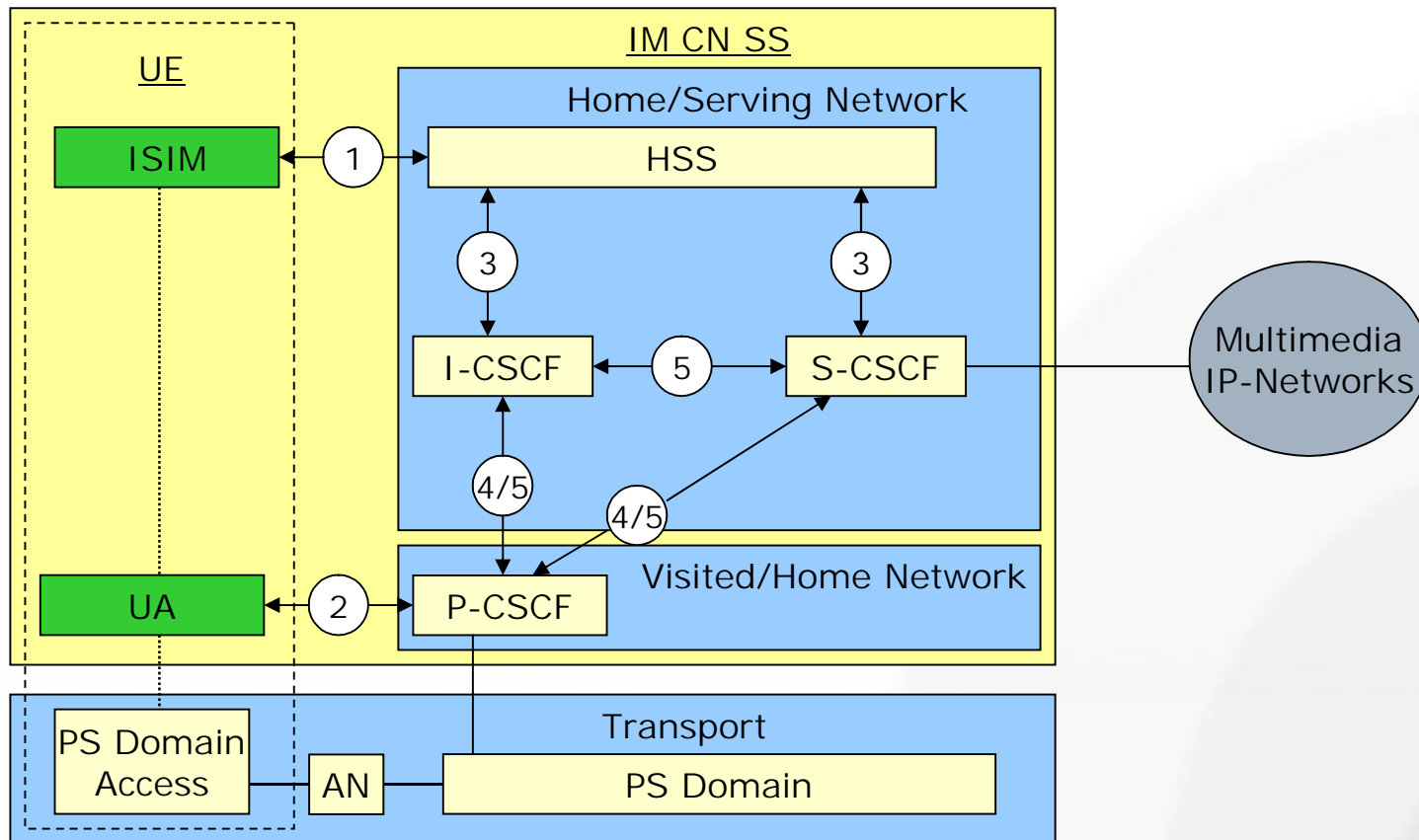

## QoS & Charging Architecture

- Policy and charging control are divided into two categories
  - Charging Control
  - Policy Control

## Basic Service Continuity

- Area of active standardisation
- Currently at stage 2 Specification

BUT...

- Enterprise reluctance

## Uniform Service Delivery

- ❑ Reduced Migration Cost
- ❑ Reduced Operational Service Deployment Cost
- ❑ Increased Vendor Interoperability
- ❑ Reasonably Future Proof

## Conclusion

- IMS is the only architecture which supports mobile, fixed and nomadic networks, although admittedly some areas do need work as far as standardisation is concerned
- 3G and WiMAX will compete, but also have to co-exist under the umbrella of IMS
  - WiMAX is data technology moving towards mobility
  - 3G is voice technology moving towards data
- The challenge for service providers is to understand which technology is better suited for their need.

## Contact us

[basit.alvi@quasi-stellar.com](mailto:basit.alvi@quasi-stellar.com)  
[basit@trc.com.pk](mailto:basit@trc.com.pk)

Thank you